



INNOVATION
PROPERTIES
GROUP

37 E 4th Ave

San Mateo, CA

 **DRAPER UNIVERSITY
HERO HANGOUT**

Premier Downtown Office

5,000 SQFT

ipgsf.com

- Fully building available in premier Downtown San Mateo Location
- Floor to ceiling window line
- Four (4) conference rooms
- Three (3) private offices
- One (1) board room
- Private outdoor patio space
- Bonus Loft Mezzanine area
- Full Kitchen
- Bathrooms with showers
- Walkable to Caltrain
- Close proximity to countless restaurants, shops, and other nearby amenities

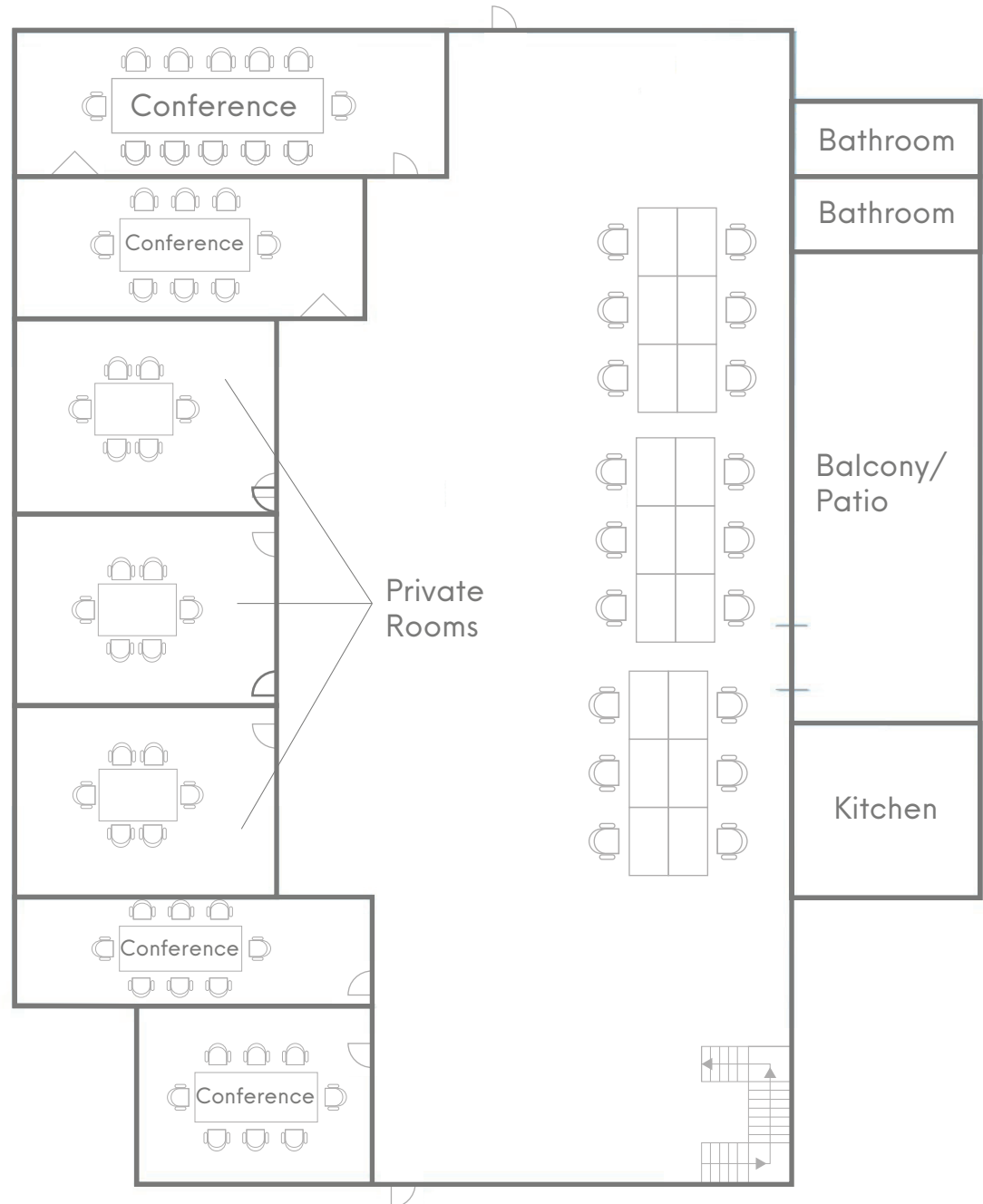



Innovation Properties Group
181 2nd Street, San Francisco, CA
www.ipgsf.com | CL 02031924

Ivan Smiljanic | Partner
(510) 717-5008 | ivan@ipgsf.com
DRE 01995999

Mitchell Hickman | Vice President
(650) 464-8890 | mitchelle@ipgsf.com
DRE 02090901





INNOVATION
PROPERTIES
GROUP

37 E 4th Ave
San Mateo, CA

 DRAPER UNIVERSITY
HERO HANGOUT

For leasing information

ipgsf.com

Innovation Properties Group

181 2nd Street, San Francisco, CA

www.ipgsf.com | CL 02031924

Ivan Smiljanic | Partner

(510) 717-5008 | ivane@ipgsf.com

DRE 01995999

Mitchell Hickman | Vice President

(650) 464-8890 | mitchell@ipgsf.com

DRE 02090901

This document has been prepared by IPG for advertising and general information only. IPG makes no guarantees, representations or warranties of any kind, expressed or implied, regarding the information including, but not limited to, warranties of content, accuracy and reliability. Any interested party should undertake their own inquiries as to the accuracy of the information. IPG excludes unequivocally all inferred or implied terms, conditions and warranties arising out of this document and excludes all liability for loss and damages arising there from. This publication is the copyrighted property of IPG and/or its licensor(s). ©2024. All rights reserved.